

### Type JSK 37 C-Z

with wear ring & external jaw lubrication

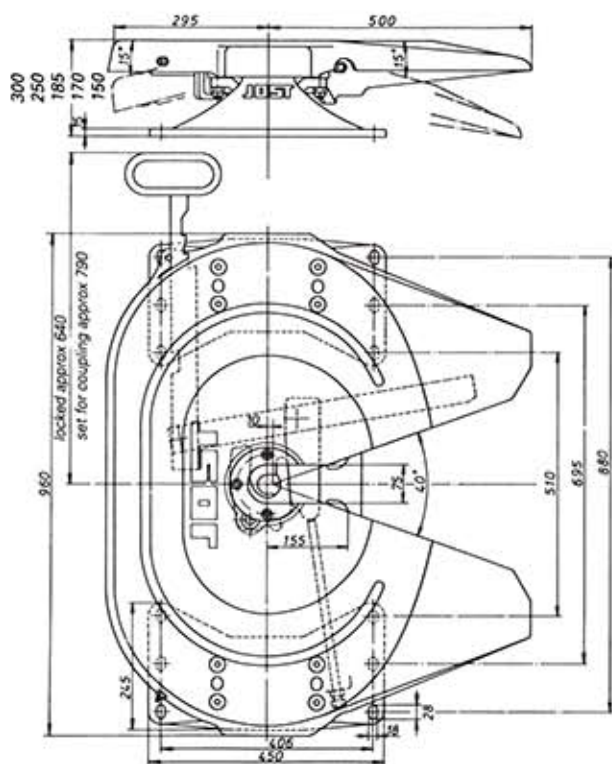

#### Applications: Tanker

General freight

Fridge van

B-double

Road train

The fifth wheel comes standard with bolt on/weld on feet.

The fifth wheel coupling can be linked to the central lubrication system of the prime mover.

Lock jaw and wear ring can be replaced without difficulty in a few minutes with the fifth wheel still in position.

Shock absorbing large rubber pads.  
Oil and grease resistant.

Mounting must be carried out in accordance with our instructions.

Type	Overall Height mm	Imposed Load On Tractor kg	D-Value kN	Weight Approx. kg	CRN
JSK 37 CZ/150	150	20000	190	144.5	24286
JSK 37 CZ/170	170	20000	190	146.5	
JSK 37 CZ/185	185	20000	190	148.5	
JSK 37 CZ/250	250	20000	190	160.5	
*JSK 37 CZ/300	300	20000	190	176.5	

\* Note 300mm non weldable pedestals

The right to alter specifications is reserved.

8/08